

# 男子部門

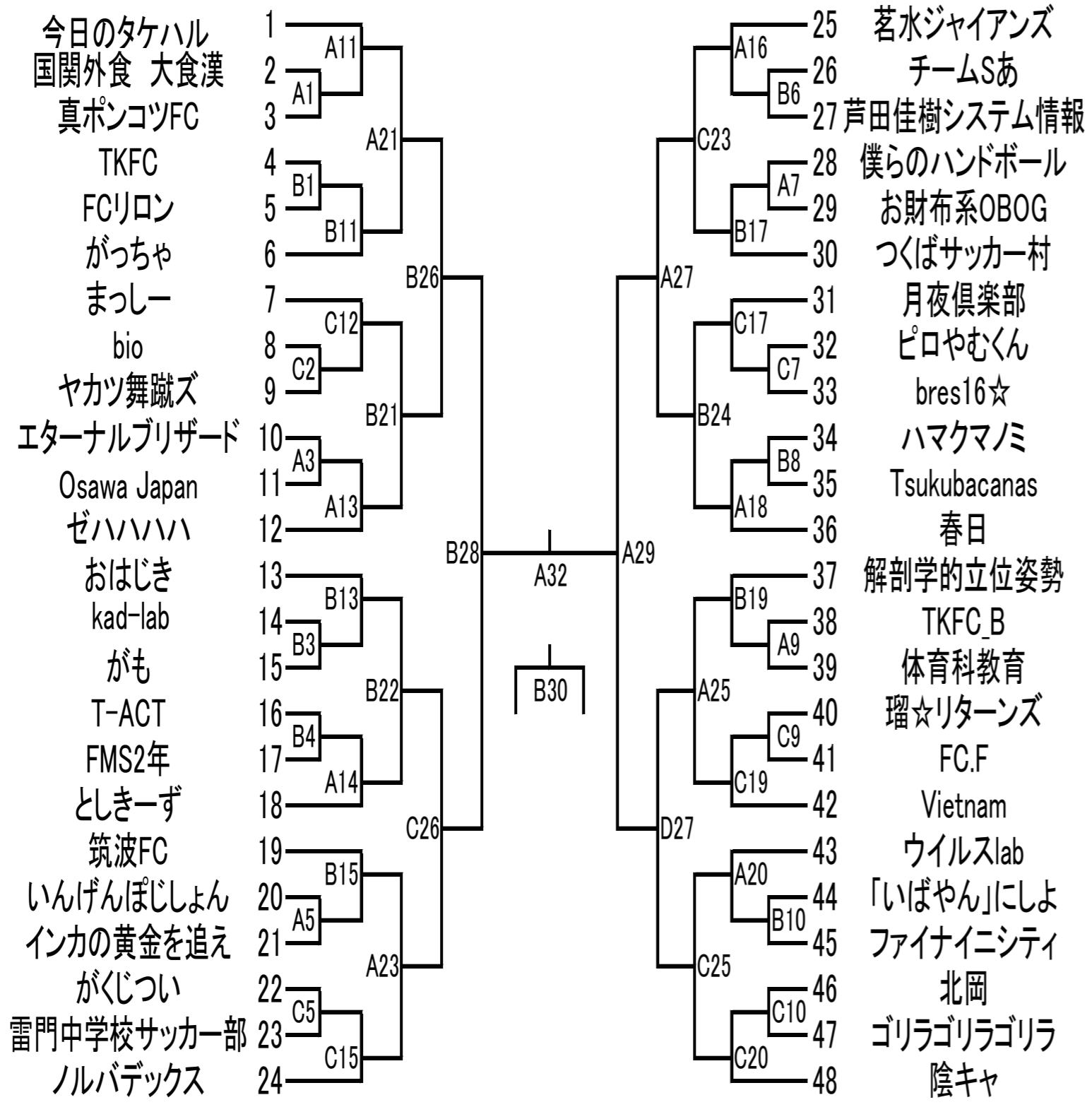

# 混合部門

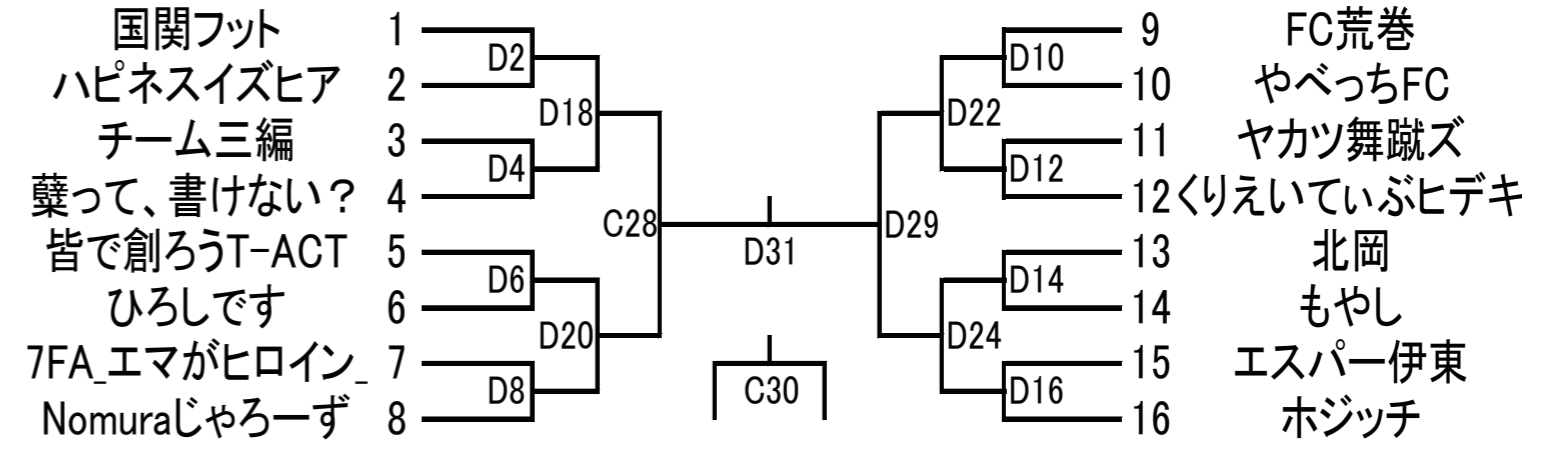

TIMETABLE			
1日目		2日目	
1	11:00	26	10:00
2	11:15	27	10:15
3	11:30	28	10:30
4	11:45	29	11:00
5	12:00	30	11:30
6	12:15	31	12:00
7	12:30	32	12:30
8	12:45		
9	13:00		
10	13:15		
11	13:30		
12	13:45		
13	14:00		
14	14:15		
15	14:30		
16	14:45		
17	15:00		
18	15:15		
19	15:30		
20	15:45		
21	16:00		
22	16:15		
23	16:30		
24	16:45		
25	17:00		

